



# Granny Square Jacket

Designed by Kim Kotary.

**Directions are for size Small; changes for sizes Medium, Large and Extra Large are in parentheses.**

**To Fit Bust:** 34 (38, 42, 46)”.  
**Finished Bust Measurement:** 35.5 (40.5, 44.5, 50)”.

**RED HEART® “Soft Yarn®”:** 1 Ball each 4601 Off White, 1882 Toast, 9518 Teal, 9779 Berry, and 4422 Tangerine; 2 (3, 3, 4) balls 4614 Black **MC**.

**Crochet Hook:** 5.5mm [US I-9].

Yarn needle

Six (6) stitch markers

Nine (9) 1” buttons.

**GAUGE:** Square measures 5.5” x 5.5”. **CHECK YOUR GAUGE. Use any size hook to obtain the gauge.**

**NOTES:** Use colors in random combinations for first 4 rnds/rows of each square or part square and Black **MC** for the last rnd/row. Join new color with right side facing.

**BASIC SQUARE: Make 29 ( 33, 33, 36)**

With color of your choice, ch 4; join with a slip st to form a ring.

**Rnd 1 (Right Side):** Ch 3, 2 dc in ring, ch 3, [3 dc in ring, ch 3] 3 times; join with a slip st to top of ch-3. Fasten off.

**Rnd 2:** Join next color in any ch-3 space; ch 3, (2 dc, ch 3, 3 dc) all in same space; \* (3 dc, ch 3, 3 dc) all in ch-3 space – **corner** made; repeat from \* around; join to top of ch-3. Fasten off.

**Rnd 3:** Join next color in any ch-3 space; ch 3, (2 dc, ch 3, 3 dc) all in same space, \* 3 dc between 3-dc groups \*\*, work corner in next ch-3 space; repeat from \* around, end at \*\*; join. Fasten off.

**Rnds 4 and 5:** Join next color in any ch-3 space; ch 3, (2 dc, ch 3, 3 dc) all in same space, \* 3 dc between 3-dc groups; repeat from \* to next corner \*\*; work corner in next ch-3 space; repeat from \* around, end at \*\*; join. Fasten off. Weave in ends.

**TRIANGLE: Make 2**

With color of your choice, ch 4; join with a slip st to form a ring.

**Row 1 (Right Side):** Ch 3 (counts as first ch-3 space), (3 dc, ch 3, 3 dc) all in ring, ch 3 (counts as last ch-3 space), slip st in ring. Fasten off.

**Row 2:** Join next color in first ch-3 space; (ch 3, 3 dc) all in same space, work corner in next ch-3 space, (3 dc, ch 3, slip st) all in last ch-3 space. Fasten off.

**Row 3:** Join next color in first ch-3 space; (ch 3, 3 dc) all in same space, 3 dc between 3-dc groups, work corner in next ch-3 space, 3 dc between 3-dc groups, (3 dc, ch 3, slip st) all in last ch-3 space. Fasten off.

**Rows 4 and 5:** Join next color in first ch-3 space; (ch 3, 3 dc) all in same space, \* 3 dc between 3-dc groups; repeat from \* to next ch-3 space \*\*; work corner in next ch-3 space; repeat from \* once more, end at \*\*; (3 dc, ch 3, slip st) all in last ch-3 space. Fasten off. Weave in ends.



**Size Small ONLY – RECTANGLE HALF SQUARE:**

**Make 4**

With color of your choice, ch 4; join with a slip st to form a ring.

**Row 1 (Right Side):** Ch 3 (counts as first ch-3 space), (dc, ch 3, 3 dc, ch 3, dc) all in ring, ch 3 (counts as last ch-3 space), slip st in ring. Fasten off.

**Row 2:** Join next color in first ch-3 space; (ch 3, dc) all in same space, [work corner in next ch-3 space] twice, (dc, ch 3, slip st) all in last ch-3 space. Fasten off.

**Row 3:** Join next color in first ch-3 space; (ch 3, dc) all in same space, work corner in next ch-3 space, 3 dc between 3-dc groups, work corner in next ch-3 space, (dc, ch 3, slip st) all in last ch-3 space. Fasten off.

**Row 4:** Join next color in first ch-3 space; (ch 3, dc) all in same space, 3 dc between dc and next 3-dc group, work corner in next ch-3 space, [3 dc between 3-dc groups] twice, work corner in next ch-3 space, 3 dc between next 3-dc group and dc, (dc, ch 3, slip st) all in last ch-3 space. Fasten off.

**Row 5:** Join **MC** in first ch-3 space; (ch 3, dc) all in same space, 3 dc between dc and next 3-dc group, 3 dc between 3-dc groups, work corner in next ch-3 space, [3 dc between 3-dc groups] 3 times, work corner in next ch-3 space, 3 dc between 3-dc groups, 3 dc between next 3-dc group and dc, (dc, ch 3, slip st) all in last ch-3 space. Fasten off. Weave in ends.

**Sizes Large and Extra Large ONLY – BACK**

**Side Panels**

Sew squares together following diagram.

**Row 1:** With right side facing, join **MC** in corner ch-3 space on side of work; ch 3, 2 dc in same space, 3 dc in each space along side; turn.

**Row 2:** Ch 3, 3 dc between 3-dc groups to last st; dc in top of ch-3; turn.

**Row 3:** Ch 3, 2 dc in space between first dc and next 3-dc group, 3 dc between 3-dc groups to last st; 2 dc in space between last 3-dc group and last st, dc in top of ch-3; turn.

**Row 4:** Repeat Row 2. Fasten off.

Repeat Rows 1-4 on opposite side of Back.

**All Sizes-FINISHING**

Sew squares together according to diagram. For size Small, ease in side square at lower tip of underarm gusset.

**EDGING**

**Rnd 1:** With right side facing, join **MC** at back neck; ch 1, sc evenly to left front triangle, 2 sc in each dc at end of each row to lower end of 3rd row, 5 dc in end of 3rd row, sc evenly down front opening, work 5 sc in left lower corner, sc evenly across back, work 5 sc in right lower corner, sc evenly up front opening, 5 dc in lower end of Row 3 of right front triangle, sc evenly to end of rnd; join with a slip st in first sc.

**Rnd 2:** Ch 1, sc in each st around working (2 sc, ch 1, 2 sc) in center st of each corner; join.

**Buttonhole Rnd 3:** Mark positions for 6 buttonholes evenly spaced along right front; ch 1, sc in each sc to lower right front and work (sc, ch 1, sc) all in ch-space at each corner; [work sc up right front to marker, ch 3, skip 3 sc] 6 times, work as established to end; join.

**Rnd 4:** Ch 1, sc in each sc around and work (sc, ch 1, sc) in ch-space at corners and 3 sc in each ch-3 space for buttonholes; join.

**Row 5:** Ch 1, sc in each sc around and work (sc, ch 1, sc) in ch-space at corners; join.

**Row 6:** Ch 1, working from left to right, work Reverse sc around. Fasten off. Weave in ends. Sew buttons to correspond to buttonholes.



**Cuffs:** With right side facing, join **MC** at sleeve edge and work 5 rnds of sc around opening. Work 1 rnd of Reverse sc. Fasten off. Weave in ends.

### Large Pocket Flaps (Make 2)

With **MC**, ch 21.

**Row 1 (Right Side):** Sc in 2nd ch from hook and in each ch across; turn – 20 sc.

**Rows 2 and 3:** Ch 1, sc in each sc across; turn.

**Row 4:** Ch 1, sc in first 18 sc; *draw up a loop in next 2 sc, yo and draw through all 3 loops on hook – **sc2tog** made;* turn – 19 sts.

**Rows 5-8:** Ch 1, sc2tog, sc to last 2 sts, sc2tog; turn – 11 sts at end of Row 8. Fasten off.

### Large Pocket Edging

With right side facing, join **MC** at end of Row 1; ch 1, work Reverse sc (work sc from left to right) around curved edge. Fasten off leaving a tail for sewing.

### Small Pocket Flap

With **MC**, ch 16.

**Row 1 (Right Side):** Sc in 2nd ch from hook and in each ch across; turn – 15 sc.

**Row 2:** Ch 1, sc in first 13 sc, sc2tog; turn – 14 sts.

**Rows 3-6:** Ch 1, sc2tog, sc to last 2 sts, sc2tog; turn – 6 sts at end of Row 6. Fasten off.

### Small Pocket Edging

Work same as Large Pocket Edging.

Sew pocket flaps as indicated on diagram; sew buttons on pocket flaps securing them to sweater front.



**RED HEART® “Soft Yarn®**, Art. E728  
available in solid colors – 5 oz (140g),  
256 yd (234m) or prints – 4 oz (113g),  
204 yd (187m) balls.

**ABBREVIATIONS:** **ch** = chain; **dc** = double crochet; **MC** = main color; **mm** = millimeters; **rnd** = round; **sc** = single crochet; **st(s)** = stitch (es); **tog** = together; **yo** = yarn over; \* or \*\* = repeat whatever follows the \* or \*\* as indicated; [ ] = work directions in brackets the number of times specified.



GRANNY SQUARE JACKET | CROCHET

BACK (SIZES S, M)

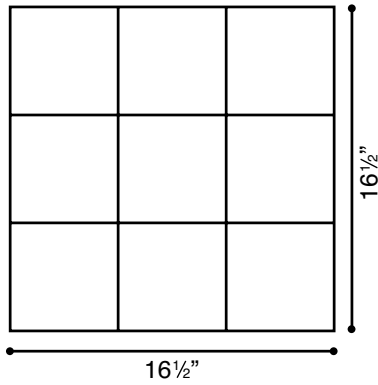

FRONT (SIZE S)

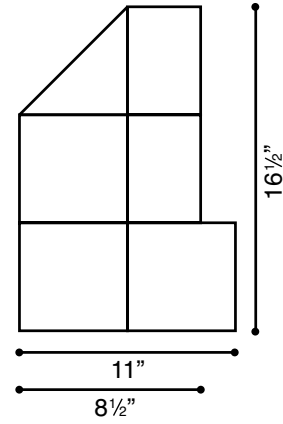

BACK (SIZE L)

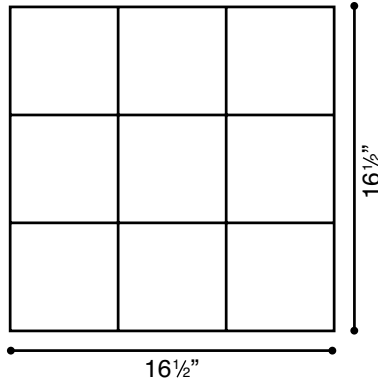

FRONT (SIZES M, L, XL)

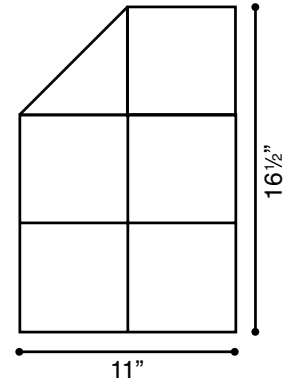

BACK (SIZE XL)

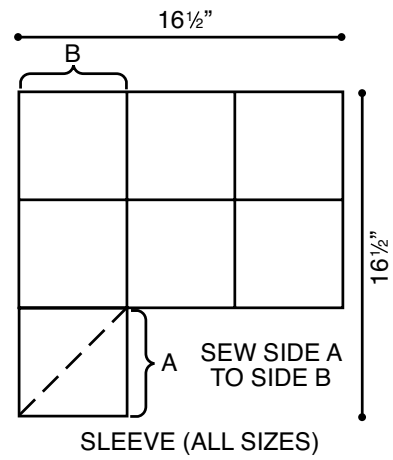
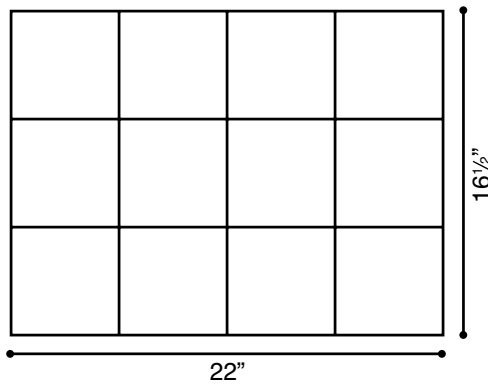



GRANNY SQUARE JACKET | CROCHET

**Assembly Diagrams**

1. Join motifs together using desired method to form Front (2), Sleeves (2) and Back pieces as shown in Schematics.
2. Join Front, Sleeves and Back along yellow lines.
3. Fold Jacket along green dotted line.
4. Form underarm gusset by joining A1 to A1 and B1 to B1.
5. Repeat for other side matching A2 to A2 and B2 to B2.
6. Join Sleeve front to Sleeve back (C1 to C1 and C2 to C2).
7. Join Front side to Back side (D1 to D1 and D2 to D2).

**Steps 1 to 5**

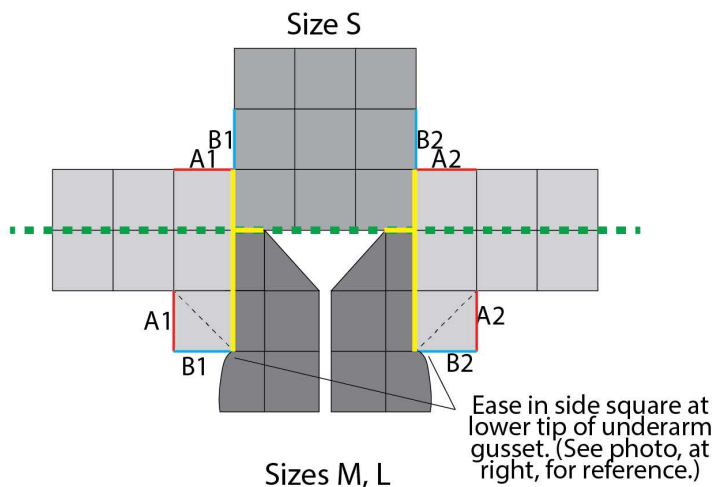

**Steps 6 to 7**

